

Senor iSPAD7

7" Intel® Atom™ Z530P Rugged Tablet PC



Features

- Ultra Low Power Consumption
- Fully Rugged for Mobile POS/Warehousing/Vehicle Computer Application
- Meets MIL-STD-810F, IP54 rated, 6 ft. Drop Resistance
- High Mobility, Multi Connectivity (Bluetooth/WLAN/3.75G/GPS)
- Multi-identification Devices (Barcode, RFID)
- Hot-swappable Dual-batteries, Providing Battery Life up to 8 Hours
- 61-key Keypad

System

CPU	Intel® Atom™ Z530P 1.6GHz processor
Graphics Controller	GMA 500 Integrated
Memory	2GB DDR2-800 SDRAM installed
Chipset	Intel® System Controller Hub US15WPT
BIOS	AMI BIOS
Audio	1 x Integrated microphone 1 x Integrated 1.5W speaker
Storage	1 x 32GB 1.8" SATA SSD

Peripherals and Devices

Serial Port	1 x RS-232 port
USB Port	2 x USB 2.0 ports
Camera	1 x 2.0 megapixels AF CMOS camera (optional)
RFID	Integrated ISO 15693/14443A/14443B RFID Reader (distance: 3~5cm; speed: 5 cards/sec)
Ethernet	1 x RJ45 GbE LAN
Wi-Fi	Integrated WLAN 802.11 b/g/n
Bluetooth	Integrated Bluetooth 2.1 + EDR
GSM/UMTS	Gobi 3000 HSUPA module (3.75G) for GSM/GPRS/EDGE, EV-DO networks (optional)
GPS	1 x GPS module (optional)
Barcode Scanner	1 x 1D/2D Barcode scanner (optional)
Expansion	1 x 35-pin pogo connector for connection with vehicle cradle
SIM Socket	1 x SIM socket (located underneath the battery pack)
Hand Strap	1 x Black elastic hand strap

Button & Indicator

	6 x Function keys
Function Key	2 x Manual buttons on the front 2 x Barcode Scanner trigger button on the sides
Power Button	1 x Power on/off button on the right side
Keypad	1 x 61-key keypad

LCD Display

Size/Type	7" wide active matrix TFT
Max. Resolution	1024 x 600 (WVGA) w/ 262,144 colors
Luminance	300 cd/m ² (typ.)
Contrast Ratio	400 : 1
Backlight Type	LED

Touch Screen

Type	Analog Resistive
Light Transparency	80% (typ.)
Controller Interface	USB Interface

Power Supply

Adapter Input	100 ~ 240VAC (Full Range)
Adapter Output	19VDC, 3.42A, 65W
Battery Type	Li-battery pack
Battery Capacity	2 x 2500mAH 3-cell
Battery Operating Time	8 hours

Mechanical & Environmental

Operating Temp.	-20 ~ 45°C (-4 ~ 113°F)
Charging Temp.	0 ~ 40°C (32 ~ 104°F)
Storage Humidity	5 to 95% (non-condensing)
Dimensions (W x D x H)	188 x 240 x 47 mm (7.4" x 9.45" x 1.85")
Gross Weight	1.7 kg (3.7 lb)
Vibration	3 Grms/ 5 ~ 500Hz/ random operation
Shock	75G peak acceleration (11 ms duration)
Transit Drop	182cm (6 feet) drop to concrete
IP Rating	IP54 (whole unit)
Regulatory	CE/FCC Class B compliant

Ordering Information

G0720-Lite	7" Intel® Atom™ Z530P rugged tablet PC with camera, Bluetooth, WiFi, RFID
-------------------	---

All specifications are subject to change without notice.

Dimensions

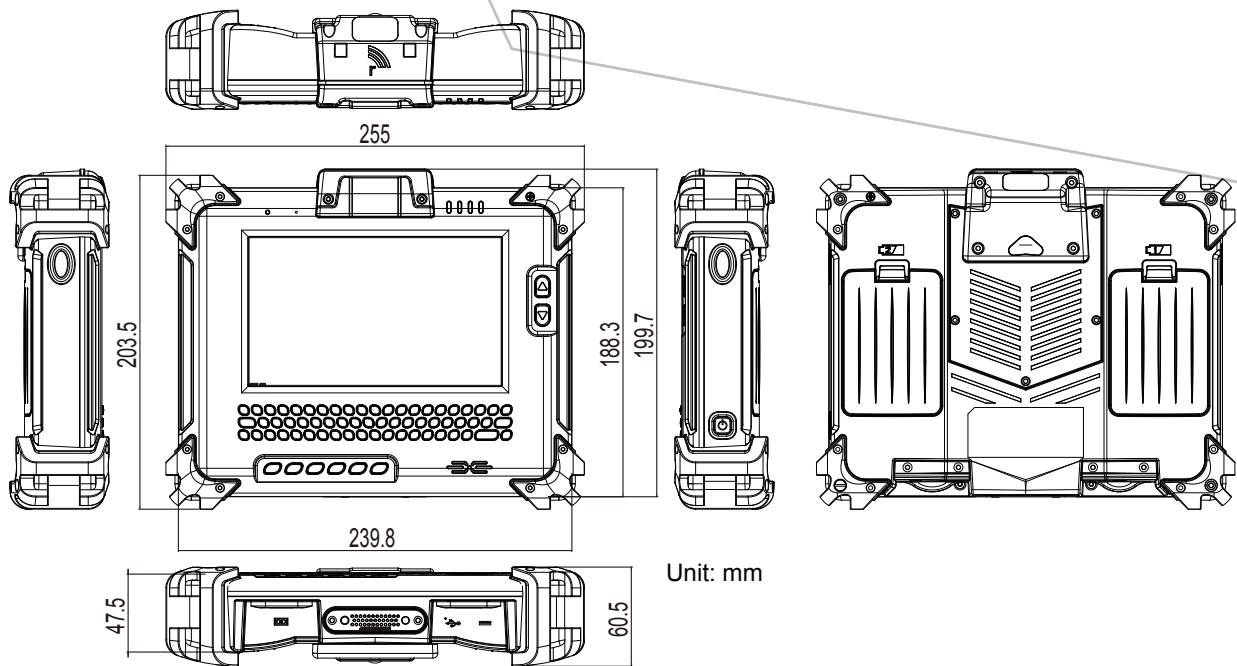

Standard Accessories

Power Adapter
19VDC, 3.42A, 65W AC/DC Adapter Kit



Battery Packs
2 x External Battery Pack Kit



HST-0720-P
1 x G0720 Hand Strap w/ Pocket



Stylus
Used for Touch Screen



Optional Accessories

VMC-0720
Vehicle Mount Cradle



HST-0720
G0720 Hand Strap



SST-0720
128*3.7cm, Shoulder Strap



eBAT-0720
External Battery Pack Kit



Optional Configuration (CTOS* Kit)

BarC-0720
1D/2D Barcode Scanner Kit



HSUPA-0720
3.75G HSUPA Wireless Kit



GPS-0720M
GPS Kit for G0720 & G0820



*CTOS means Configure to Order Service.

*GPS can only be installed while Barcode and RFID are removed.

