

CashPlus Mini

CashPlus is a generic portfolio of cash drawers, and has been selected from over 10,000 designs to reflect the unparalleled quality and flexibility that is customary to all Cash Bases products. Each drawer offers unique features, configurable inserts and variable dimensions, suitable for any retail environment, anywhere in the world.

DESCRIPTION

The small footprint of the cash drawer optimises both merchandising space and the cashiers' working area.

FEATURES

- Robust steel construction
- Steel ball bearing runners
- Drawer status micro switch
- Bolt down facility in base

OPTIONS

- A range of inserts
- Fixed or removable coin cups
- Coin cups suitable for weigh counting
- Media posting slot
- Lockable lid for the insert
- Emergency key release, 3 position or no lock
- Alike or random locks
- Support bracket for under counter mounting
- Rear cable guard for cable management

SPECIFICATION

- Width: 413mm
- Depth: 305mm
- Height: 142mm
- Weight: 10.5kg

IDEAL FOR

- Fashion Retail
- Chemists
- Speciality Retailers

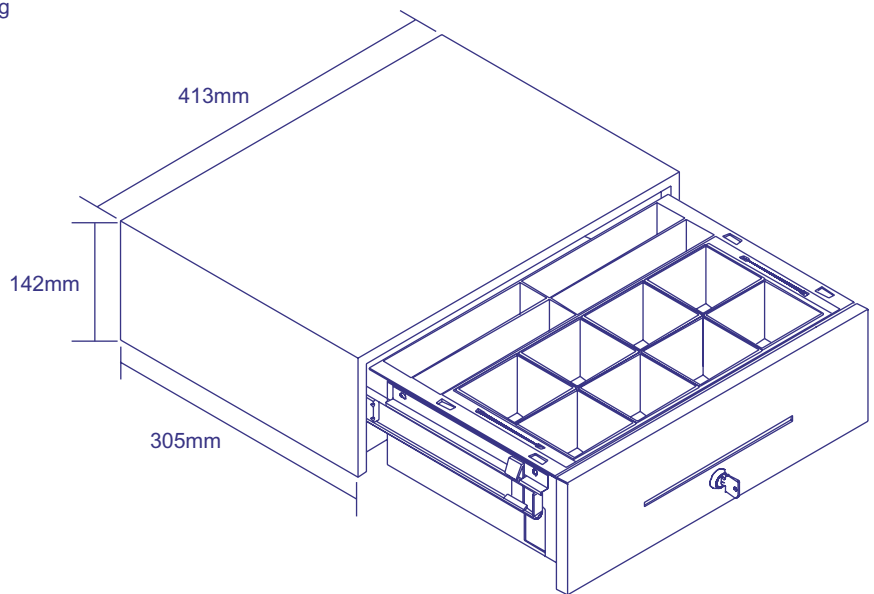

model: mini



option: 4 notes + 8 coins insert



option: 6 notes + 6 coins insert

UK/CASH-MINI/0803

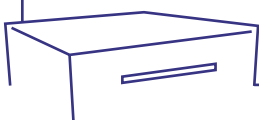

Specification may be subject to change without notification

CASHPlus

CASH BASES LTD ■ NEWHAVEN, EAST SUSSEX BN9 0LA ■ UK ■ www.cashbases.net
TEL: +44 [0] 1273 616300 ■ FAX: +44 [0] 1273 512010 ■ EMAIL: sales@cashbases.co.uk