



ALR-9800 ENTERPRISE RFID READER



FEATURES

- Multi-protocol reader designed for Gen 2
- High performance RFID capability
- Enterprise scalable, upgradeable architecture
- Dense reader management and interference mitigation
- Low initial cost of implementation
- Low ongoing cost of ownership
- Backward compatible with popular ALR-9780



95011012600000155

EPC Gen 2 RFID Reader

The Alien® ALR-9800 Enterprise RFID Reader enables users to deploy manageable, robust, best-in-class RFID across the supply chain. The unit uses an XScale processor running Linux for system and network management and a powerful DSP processor for high-performance RFID protocol implementation.

The XScale/Linux system hosts the Alien Reader Protocol and a suite of configuration and remote management functions, enabling fast, scalable implementation. The DSP architecture ensures exceptional performance for existing RFID protocols, including the EPC Gen 2 standard, while enabling implementation of future protocols, thereby protecting the user's investment.

High Performance RFID Designed with Gen 2 in Mind

The ALR-9800 extends the best-in-class EPC Class 1 capability established in previous Alien readers by adding support for EPC Class 0, 0+, Class 1 and Class 1 Gen 2 tags. Interleaved protocol implementation delivers efficient support for mixed populations with minimal switching overhead, retaining high read rates in demanding applications such as dock door and high-speed conveyors.

Enterprise Scalable Architecture for Lower Cost of Implementation and Ongoing Management

The ALR-9800 enables enterprise-wide scaling of RFID by reducing the cost of ownership at implementation and on an ongoing basis.

Lower implementation costs

Installers can upload and download configurations allowing them to program the reader once for a given configuration, and then re-use the configuration at multiple read stations. Standard configuration options provide simplicity for common situations.

The ALR-9800 reduces the cost of ancillary hardware used to integrate the reader with sensors, indicators and actuators. High capacity, optically isolated, general-purpose I/O (GPIO) signals can drive many external devices directly, eliminating the need for

costly digital I/O equipment and relays. Optical isolation ensures accurate reception of triggering signals in noisy, industrial environments.

The ALR-9800 does not require dedicated, separate, transmit and receive antennas to achieve top read rates. The multistatic antenna system achieves the performance of independent transmit and receive antennas without the cost of doubling the number of antennas. Only four single-element antennas are required for four read points, unlike other readers that require 8 antennas.

Integrated management and monitoring for lower ongoing cost

Alien pioneered the network-ready RFID reader with the ALR-9780 and its widely-supported Alien Reader Protocol. The ALR-9800 adds enhancements such as support for Simple Network Management Protocol (SNMP), which enables the network to monitor real-time health, revision and status information from the reader. The reader supports network firmware upgrades as well.

Enhanced reliability and ruggedness for improved uptime

The ALR-9800 features a rugged, steel enclosure that meets the IP54 standard for dust and moisture resistance. Heavy-duty, locking connectors ensure reliable connections even in environments with high levels of vibration. Extensive reliability testing including shock, vibration, temperature and humidity ensures field reliability.

Power loss recovery

Upon restoration of power after a power loss, the ALR-9800 resumes its previous configuration and operational mode. A tag list of up to 2500 tags may be stored in non-volatile memory.



Figure 2: A complete developer's kit for Java and .Net environments is available.



Figure 1: The ALR-9800 is available with linear or circular antennas

Dense Reader Management

The ALR-9800 employs several methods that, in combination, effectively mitigate interference.

Dense Reader Mode

The reader is compliant with Dense Reader Mode as defined in the Class 1 Gen 2 specification. Employing "dense reader channelized signaling," the ALR-9800 makes more efficient use of the available spectrum, enabling more readers to operate in close proximity when Gen 2 tags are used exclusively.

Listen-Before-Talk

The ALR-9800 employs a proprietary, patent-pending LBT methodology that allows readers to avoid transmitting on an occupied channel until the channel is available.

Event-triggered operation and Autonomous Mode

The Autonomous Mode functionality of the Alien Reader Protocol enables the reader to collect tag data when triggered by external events detected by electric eyes and other sensors. In this mode, readers are

activated only when needed, thereby reducing the on-time of each reader and lowering the number of readers operating at any given moment. This simple, but powerful tool is a critical part of co-locating large numbers of readers in a single facility.

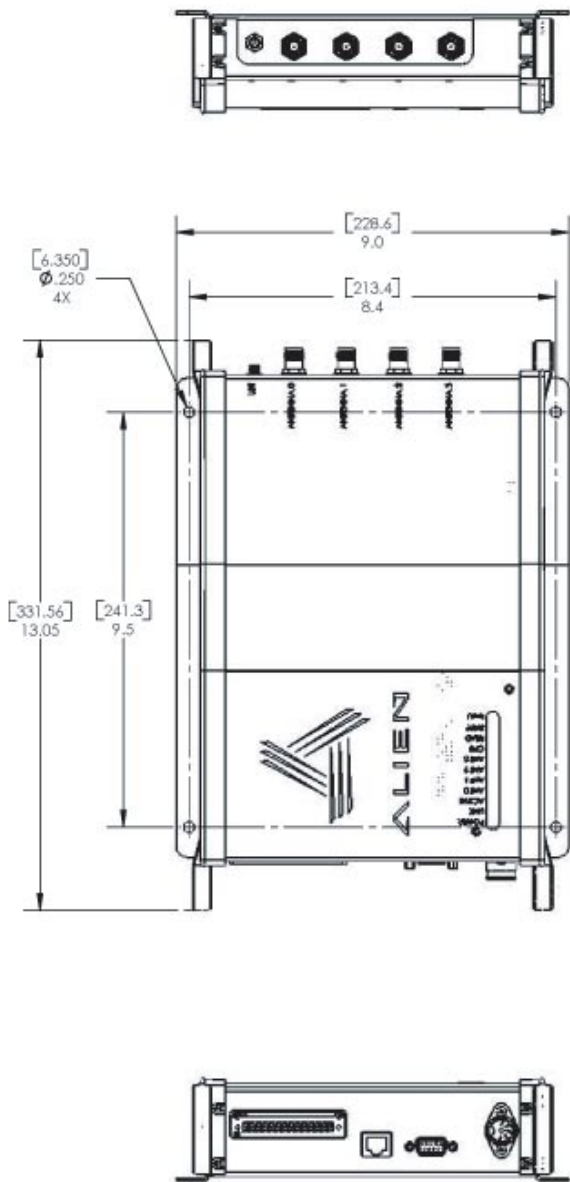

Figure 3: The ALR-9800 Enterprise RFIDReader



ALIEN.

Alien Technology

18220 Butterfield Blvd.

Morgan Hill, CA 95037

866-RFID NOW

www.alientechnology.com

| | |
|--------------------------------|--|
| MODEL NUMBER | ALR 9800 |
| ARCHITECTURE | XScale processor, Linux, 64 Mbytes RAM, 32 MBytes Flash |
| FREQUENCY | 902.75 MHz – 927.25 MHz |
| SUPPORTED RFID TAG PROTOCOLS | EPC C0,0+, C1, C1G2; Future Protocols: ISO 18000-6c, UHF battery |
| REMOTE MANAGEMENT PROTOCOLS | SNMP, Alien Reader Protocol, EPC reader protocols (pending ratification) |
| NETWORK PROTOCOLS | DHCP, TCP/IP, SNMP |
| DENSE READER MANAGEMENT | Dense Reader Mode, Clean Spectrum, Listen-before-talk, Auto triggering and event management |
| READER COMMUNICATION PROTOCOL | Alien Reader Protocol, EPC reader protocols (pending ratification) |
| HOPPING CHANNELS | 50 |
| CHANNEL SPACING | 500 KHz |
| RF POWER | 30 dBm; 4 watts EIRP |
| POWER | AC/DC power converter; 45 Watts maximum (120 or 240 VAC) |
| COMMUNICATIONS | RS-232 (DB-9 F), LAN TCP/IP(RJ-45) |
| ANTENNAS | 4 ports for 4 read points; multistatic topology; circular or linear polarization, 6 meter cables, reverse polarity TNC |
| GENERAL PURPOSE INPUTS/OUTPUTS | 4 inputs, 8 outputs, optically isolated, 0.5 amp current capacity |
| DIMENSIONS | (L) 11" (28 cm) x (W) 9.0" (22.9 cm) x (D) 2.22" (5.6 cm) |
| WEIGHT | 2.0 kg (4.4 lb) |
| OPERATING TEMPERATURE | -20°C to +50°C (-4°F to +122°F) |
| DUST AND MOISTURE | IP54 |
| LED INDICATORS | Power, Link, Active, Ant 0-3, CPU, Read, Sniff, Fault (red) |
| SOFTWARE SUPPORT | Java and .NET APIs for Alien Reader Protocol, (Alien Gateway demo app) |
| COMPLIANCE CERTIFICATION | FCC Part 15 |